

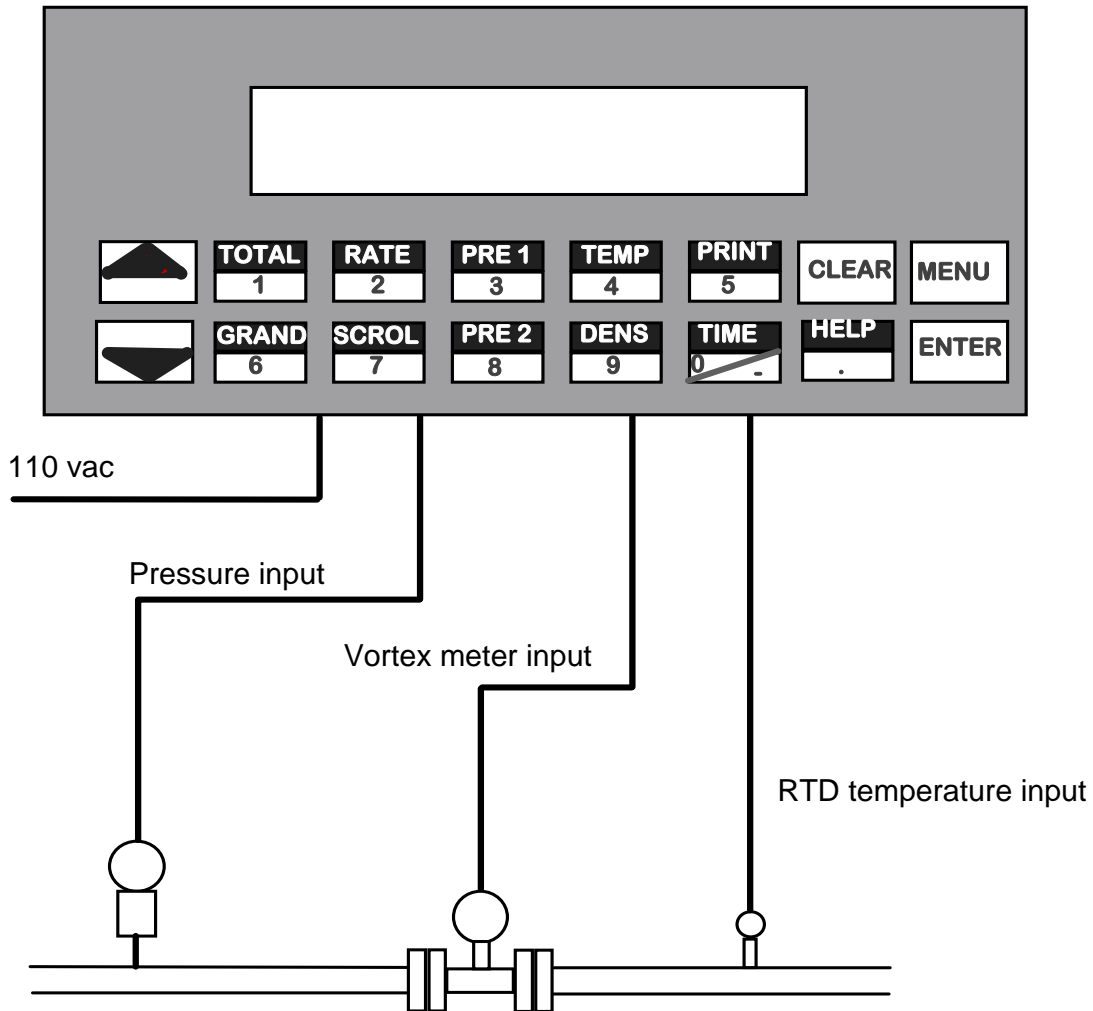

Kessler-Ellis Application Note F018

## SUPERtrol II Monitoring Steam Mass Flow



The SUPERtrol utilizes the pressure and temperature signals as an entry point to its internally held steam tables, the density of the steam is then computed. The signal from the Vortex meter, which is proportional to volumetric steam flow, is then multiplied by the density in order to yield the mass flow of steam.

The SUPERtrol provides displays of mass flow, heat flow, mass total, heat total, pressure, temperature, specific volume and specific enthalpy.

Pulse, mA, relay and RS232 outputs are provided as well as a 24 vdc 100 mA power supply for powering all process transmitters.

### Application Terminal Connections

